

3-2002

Enumerating Foldings and Unfoldings Between Polygons and Polytopes

Erik D. Demaine
University of Waterloo

Martin L. Demaine
University of Waterloo

Anna Lubiw
University of Waterloo

Joseph O'Rourke
Smith College, jorourke@smith.edu

Follow this and additional works at: https://scholarworks.smith.edu/csc_facpubs

Part of the [Computer Sciences Commons](#), and the [Geometry and Topology Commons](#)

Recommended Citation

Demaine, Erik D.; Demaine, Martin L.; Lubiw, Anna; and O'Rourke, Joseph, "Enumerating Foldings and Unfoldings Between Polygons and Polytopes" (2002). Computer Science: Faculty Publications, Smith College, Northampton, MA.
https://scholarworks.smith.edu/csc_facpubs/63

This Article has been accepted for inclusion in Computer Science: Faculty Publications by an authorized administrator of Smith ScholarWorks. For more information, please contact scholarworks@smith.edu

Enumerating Foldings and Unfoldings between Polygons and Polytopes

Erik D. Demaine¹, Martin L. Demaine¹, Anna Lubiw¹, and Joseph O’Rourke²

¹ Dept. Comput. Sci., Univ. of Waterloo, Waterloo, ON N2L 3G1, Canada.
{eddemaine,mldemaine,alubiw}@uwaterloo.ca.

² Dept. Comput. Sci., Smith College, Northampton, MA 01063, USA.
orourke@cs.smith.edu.

Abstract. We pose and answer several questions concerning the number of ways to fold a polygon to a polytope, and how many polytopes can be obtained from one polygon; and the analogous questions for unfolding polytopes to polygons. Our answers are, roughly: exponentially many, or nondenumerably infinite.

1 Introduction

We explore the process of folding a simple polygon by gluing its perimeter shut to form a convex polyhedron, and its reverse, cutting a convex polyhedron open and flattening its surface to a simple polygon. We restrict attention to convex polyhedra (henceforth, *polytopes*), and to simple (i.e., nonself-intersecting, nonoverlapping) polygons (henceforth, *polygons*). The restriction to nonoverlapping polygons is natural, as this is important to manufacturing applications [O’R00]. The restriction to convex polyhedra is made primarily to reduce the scope of the problem. See [BDD⁺98] and [BDEK99] for a start on unfolding nonconvex polyhedra.

We enumerate foldings and unfoldings based on two criteria of indistinguishability: geometric congruence, and combinatoric equivalence. The latter especially will need further specification to become precise, but to presage our results crudely, we show that both the number of foldings and the number of unfoldings can be exponential in the number of vertices n of the polygon/polytope. Similarly, we show that polygons may fold and polytopes unfold to an infinite number of incongruent polytopes/polygons. We obtain sharper results when attention is restricted to convex polygons. Proofs and details not provided here may be found in [DDLO00].

We will use P throughout the paper for a polygon, and Q for a polytope, ∂P and ∂Q respectively for their boundaries, and n for the number of their vertices.

2 Aleksandrov’s Theorem

A key tool in our work is a far-reaching generalization of Cauchy’s rigidity theorem proved by Aleksandrov [Ale58] that gives simple conditions for any folding

to a polytope. A *gluing* maps ∂P to ∂P in a length-preserving manner, as follows. ∂P is partitioned by a finite number of distinct points into a collection of open intervals whose closure covers ∂P . Each interval is mapped one-to-one (i.e., *glued*) to another interval of equal length. Corresponding endpoints of glued intervals are glued together (i.e., identified). Finally, gluing is considered transitive: if points a and b glue to point c , then a glues to b . Aleksandrov proved that any gluing that satisfies these two conditions corresponds to a unique polytope:

1. No more than 2π total face angle is glued together at any point; and
2. The complex resulting from the gluing is homeomorphic to a sphere.

We call a gluing that satisfies these conditions an *Aleksandrov gluing*. Although an Aleksandrov gluing of a polygon forms a unique polytope, it is an open problem to compute the three-dimensional structure of the polytope [O’R00]. Henceforth we will say a polygon *folds* to a polytope whenever it has an Aleksandrov gluing.

We should mention two features of Aleksandrov’s theorem. First, the polytope whose existence is guaranteed may be *flat*, that is, a doubly-covered convex polygon. We use the term “polytope” to include flat polyhedra. Second, condition (2) specifies a face angle $\leq 2\pi$. The case of equality with 2π leads to a point on the polytope at which there is no curvature, i.e., a nonvertex. We make explicit what counts as a vertex below.

3 Geometrical Congruence

In this section we address these two natural questions:

1. How many geometrically different polytopes may be folded from one polygon?
2. How many geometrically different polygons may be unfolded from one polytope?

Here “geometrically different” means incongruent. Although we mentioned the rough answer to both question is ‘infinite,’ there are several nuances in the details. For example, the answer to the first question is: ‘sometimes infinite,’ whereas the answer to the second is: ‘always infinite.’

3.1 Congruence: Folding

We start with a natural and easily proved claim:

Lemma 1. *Some polygons cannot be folded to any polytope.*

An example is shown in Fig. 1.

It is natural to wonder what the chances are that a random polygon could fold to a polytope. This is difficult to answer without a precise definition of “random,” but we feel any reasonable definition would lead to the same answer:

ZERO. We provide support for this conjecture in [DDLO00]. Despite this evidence for the rare ability to fold, convex polygons are fertile in their folding, as we now demonstrate.

Let $x \in \partial P$ be an arbitrary point on the boundary of P , and let $y \in \partial P$ be the midpoint of perimeter L around ∂P measured from x . Let (x, y) be the open interval of ∂P counterclockwise from x to y . Define a *perimeter-halving gluing* as one which glues (x, y) to (y, x) . A consequence of Aleksandrov’s theorem is:

See Fig. 2 for an example.

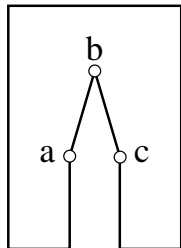

Fig. 1. An unfoldable polygon.

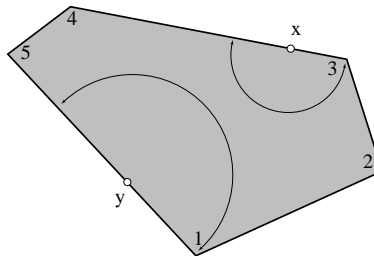

Fig. 2. A perimeter-halving fold of a pentagon. The gluing mappings of vertices v_1 and v_3 are shown.

Lemma 2. *Every convex polygon folds to a polytope via perimeter halving for every $x \in \partial P$.*

This result can be strengthened:

Theorem 1. *Any convex polygon P folds, via perimeter halving, to a nondenumerably infinite number of noncongruent polytopes.*

Using a different type of folding, we can show that every rectangle folds to a continuum of tetrahedra. See Fig. 3.

3.2 Congruence: Unfolding

Although it is a long-standing open problem to determine whether every polytope may be cut *along polytope edges* and unfolded to a polygon, without the “along edges” restriction it is easy to see that every polytope may be cut open to a continuum of noncongruent polygons. To avoid trivial zigzaging of the cuts, it makes sense to restrict the cuts to be *geodesics*, which unfold (or “develop”) to straight lines, or restrict even further to *shortest paths*, geodesics which are in addition shortest paths between their endpoints. Still this holds:

Lemma 3. *Every polytope Q may be cut via shortest paths to unfold to a nondenumerably infinite number of noncongruent polygons.*

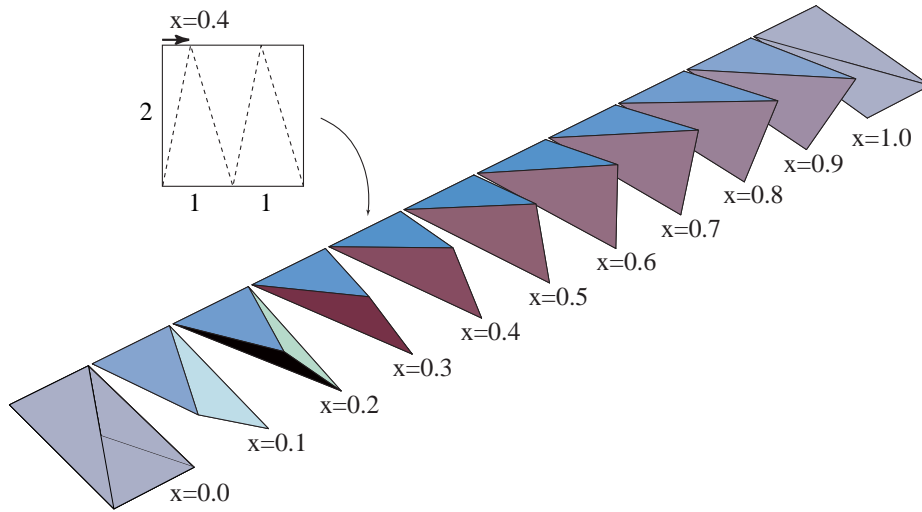

Fig. 3. Tetrahedra formed by folding a rectangle.

Proof: (*Sketch*) This may be accomplished via the star-unfolding [AAOS97], which cuts along the shortest paths from a source point s to every vertex of Q . For any point p in the interior of a “ridge-free region” of ∂Q , every s in a neighborhood of p yields a distinct star-unfolding. \square

4 Combinatorial Equivalence

Although a natural counterpart to our geometric enumerations would count combinatorially distinct polygons and polytopes, the former class is uninteresting and the latter class seems difficult to capture.¹ Instead we focus on the *process* of folding and unfolding, and ask:

1. How many combinatorially different foldings of a polygon lead to a polytope?
2. How many combinatorially different cuttings of a polytope lead to polygon unfoldings?

It requires some care to define an appropriate notion of “combinatorially different” for both questions.

4.1 Combinatorics: Folding

We capture the combinatorics of a polygon folding via its “gluing tree.” Let a polygon P have vertices v_1, \dots, v_n , labeled counterclockwise, and edge e_i , $i = 1, \dots, n$ the open segment of ∂P after v_i . The *combinatorial gluing tree* T_G is a labeled tree representing the identification of ∂P with itself. Any point of ∂P

¹ Some results for convex unfoldings were obtained by Shephard [She75].

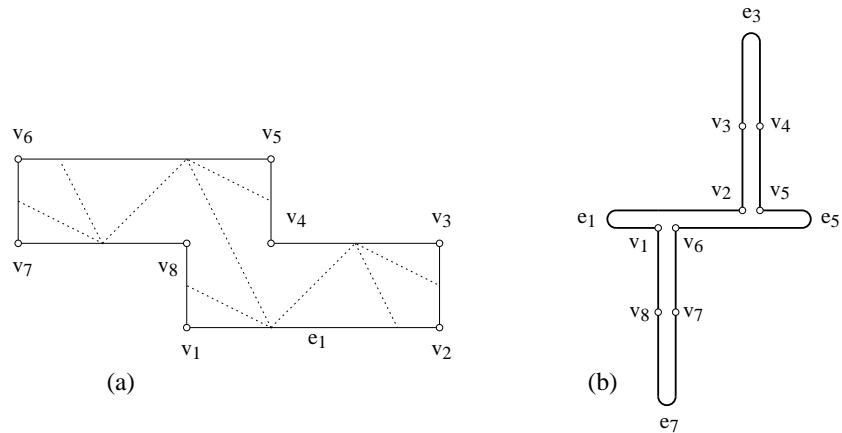

Fig. 4. (a) A polygon, with fold creases shown dotted; (b) A gluing tree T_G [folding away] corresponding to the crease pattern.

that is identified with more or less than one other distinct point of ∂P becomes a node of T_G , as well as any point to which a vertex is glued. (Note that this means there may be nodes of degree 2.) So every vertex of P maps to a node of T_G ; each node is labeled with the set of all the elements (vertices or edges) that are glued together there. A point of ∂P in the interior of a polygon edge that glues only to itself, i.e., where a crease folds the edge in two, we call a *fold point*. Points x and y in Fig. 2 are fold points. A fold-point correspond to a leaf of T_G , and is labeled by the edge label only. Every nonleaf node has at least one vertex label, and at most one edge label. An example is shown in Fig. 4. The polygon shown folds to a tetrahedron by creasing as illustrated in (a). All four tetrahedron vertices are fold points. The corresponding gluing tree is shown in (b) of the figure. The two interior nodes of T_G have labels $\{v_1, v_6, e_1\}$ and $\{v_2, v_5, e_5\}$.

We start with a characterization of the structure of gluing trees, which will form the basis of our enumeration results. Several combinatorial tree structures play a special role, and to which we assign symbols:

1. | : a path.
2. Y : a tree with a single degree-3 node.
3. I : a tree with two degree-3 nodes connected by an edge (e.g., Fig. 4b).
4. † : a tree with single degree-4 node.

Next, define a *belt* in a gluing tree to be a path between two leaf fold points; for example, between the e_1 and e_3 fold points in Fig. 4b. A belt is a *rolling belt* if there is a nonzero-length interval $I \subset e$ such that for every $x \in I$, the belt folded at x is an Aleksandrov gluing. (A belt could instead have a finite number of distinct gluings, perhaps just one.)

Our characterization shows that gluing trees are fundamentally discrete structures, with one or two rolling belts, and two such belts only in very special circumstances:

Theorem 2. *Gluing trees satisfy these properties:*

1. *At any gluing tree point of degree $d \neq 2$, at most one point of ∂P in the interior of an edge may be glued, i.e., at most one nonvertex may be glued there.*
2. *At most four leaves of the gluing tree can be fold points, i.e., points in the interior of an edge of ∂P . The case of four fold-point leaves is only possible when the tree has exactly four leaves, with the combinatorial structure ‘+’ or ‘I’.*
3. *A gluing tree can have at most two rolling belts.*
4. *A gluing tree with two rolling belts must have the structure ‘I’, and result from folding a polygon that can be viewed as a quadrilateral with two of its opposite edges replaced by complementary polygonal paths.*

Thus a generic gluing tree has one rolling belt, with trees hanging off it, and one of those trees having a fold-point leaf, as depicted in Fig. 5.

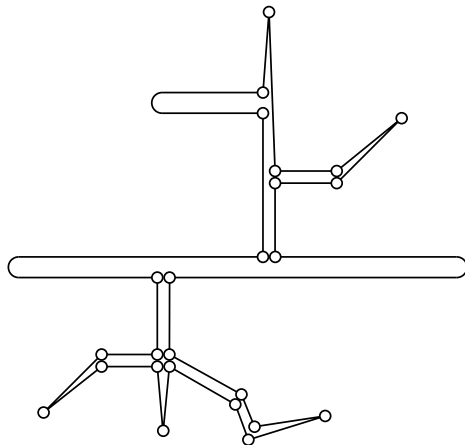

Fig. 5. A generic gluing tree: three fold-point leaves (indicated by smooth arcs), two forming a rolling belt. Vertices indicated by open circles.

We use this characterization to prove bounds on the number of gluings. First, a lower bound:

Theorem 3. *For any even n , there is a polygon P of n vertices that has $2^{\Omega(n)}$ combinatorially distinct Aleksandrov gluings.*

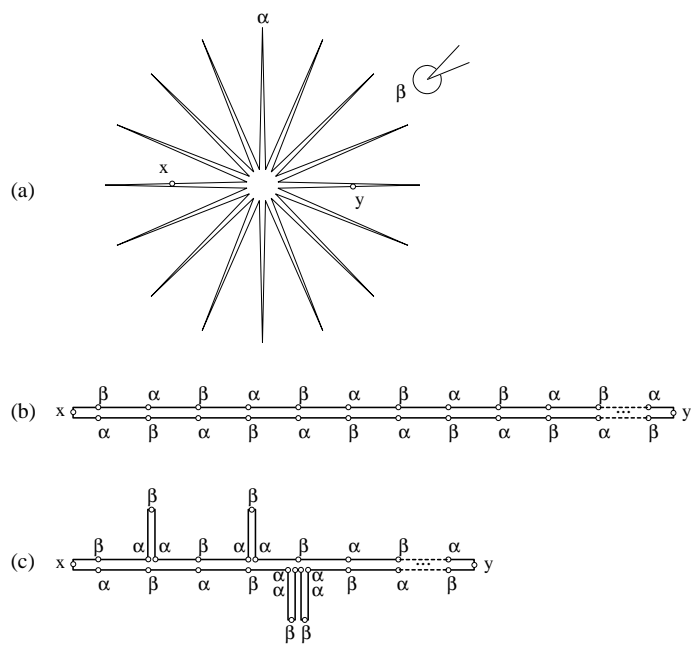

Fig. 6. (a) Star polygon P , $m = 16$, $n' = 32$, $n = 34$. (b) Base gluing tree. (c) A gluing tree after several contractions.

Proof: (*Sketch*) The polygon P is illustrated in Fig. 6(a). It is a centrally symmetric star, with m vertices, m even, with a small convex angle $\alpha \approx 0$, alternating with m vertices with large reflex angle $\beta < 2\pi$. All edges have the same (say, unit) length. We call this an m -star. We choose α small enough so that m copies of α can join with one of β and still be less than 2π . Now we add two vertices x and y at the midpoints of edges, symmetrically placed so that y is half the perimeter around ∂P from x . Let $n = n' + 2$ be the total number of vertices of P .

The “base” gluing tree is illustrated in Fig. 6(b). x and y are fold vertices of the gluing. Otherwise, each α is matched with a β . Because all edge lengths are the same, and because $\alpha + \beta < 2\pi$, this path is an Aleksandrov gluing. We label it $T_{00\dots 0,00\dots 0}$, where $m/2$ zeros $00\dots 0$ represent the top chain, and another $m/2$ zeros represent the bottom chain.

The other gluing trees are obtained via “contractions” of the base tree. A *contraction* makes any particular β -vertex not adjacent to x or y a leaf of the tree by gluing its two adjacent α -vertices together. Label a β -vertex 0 or 1 depending on whether it is uncontracted or contracted respectively. Then a series of contractions can be identified with a binary string. For example, Fig. 6(c) displays the tree $T_{010100\dots,00110\dots 0}$.

We can bound the number of Aleksandrov gluings resulting from these contractions by $\Omega(2^{m/2-1}) = 2^{\Omega(n)}$. \square

It may not be surprising that some polygons have many foldings, but it is perhaps less intuitive that even simple polygonal shapes have many gluings. For example, our enumeration program finds that an equilateral triangle has 19 gluings and a square 43 gluings. Of the latter, 10 foldings are distinct when symmetries are removed: several flat shapes, four tetrahedra, a hexahedron, and a continuum of octahedra. Hirata [Hir00] has shown that the Latin square, whose study we initiated in [LO96], has 85 distinct gluings. These lead to 21 distinct shapes, including several flat quadrangles, tetrahedra, hexahedra (including a cube), octahedra, and a pentahedron.² Fig. 7 shows crease patterns for two gluings.

We may obtain an upper bound in terms of the number of leaves λ of the gluing tree:

Theorem 4. *The number of gluing trees with λ leaves for a polygon P with n vertices is $O(n^{2\lambda-2})$.*

This bound is useful when the number of leaves is bounded, which is the case, for example, with convex polygons. The characterization of Theorem 2 can be tightened in this case:

Lemma 4. *For convex polygons, the gluing tree T_G has one of these combinatorial structures: when $n \neq 4$, either ‘|’ or ‘Y’; when $n = 4$, in addition ‘I’ and ‘+’ are possible.³*

² <http://daisy.uwaterloo.ca/~eddemain/aleksandrov/cross/> .

³ This lemma is largely due to Shephard [She75].

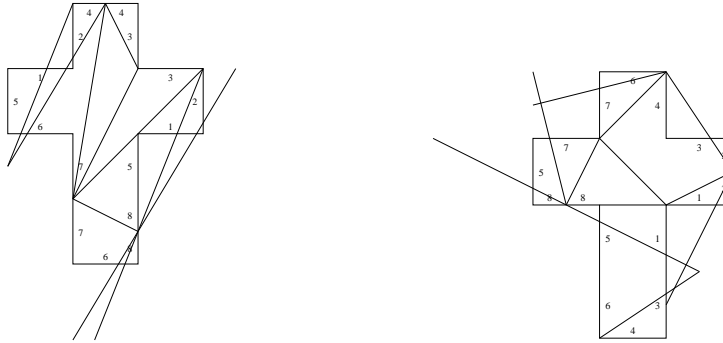

Fig. 7. Construction lines for creases to fold a Latin cross to a hexahedron (left) and a pyramid with a quadrangular base (right).

This leads to a tighter bound for convex polygons:

Theorem 5. *A convex polygon P of n vertices folds to at most $O(n^3)$ different gluing trees. Some convex polygons have $\Omega(n^2)$ gluings.*

We leave open the task of closing the gap between quadratic and cubic.

4.2 Combinatorics: Unfolding

Finding the “right” way to count unfoldings is more delicate. We start by defining cut trees, which then form the basis of our enumerations. It will be useful to distinguish between a *geometric* tree \mathcal{T} composed of a union of line segments, and the more familiar *combinatorial* tree T of nodes and arcs. A *geometric cut tree* \mathcal{T}_C for a polytope Q is a tree drawn on ∂Q , with each arc a polygonal path, which leads to a polygon unfolding when the surface is cut along \mathcal{T} , i.e., flattening $Q \setminus \mathcal{T}$ to a plane.

Lemma 5. *If a polygon P folds to a polytope Q , ∂P maps to a tree $\mathcal{T}_C \subset \partial Q$, the geometric cut tree, with the following properties:*

1. \mathcal{T}_C is a tree.
2. \mathcal{T}_C spans the vertices of Q .
3. Every leaf of \mathcal{T}_C is at a vertex of Q .
4. A point of \mathcal{T}_C of degree d (i.e., one with d incident segments) corresponds to exactly d points of ∂P . Thus a leaf corresponds to a unique point of ∂P .
5. Each arc of \mathcal{T}_C is a polygonal path on Q .

There are several options in defining the combinatorial tree T_C for a geometric \mathcal{T}_C :

1. Make every segment of \mathcal{T}_C an arc of T_C . Although this is natural, allowing an arbitrarily complicated polygonal path between any two polytope vertices leads to an infinite number of different cut trees for any polytope.

2. Make every point where a path of \mathcal{T}_C crosses an edge of the polytope a node of T_C . This again leads to trivially infinite numbers of cut trees when a path of \mathcal{T}_C zigzags back and forth over an edge of Q .
3. Exclude this possibility by forcing the paths between polytope vertices to be geodesics, and again make polytope edge crossings nodes of T_C . This excludes many interesting cut trees and destroys symmetry between T_C and T_G .
4. Make every maximal path of \mathcal{T}_C consisting only of degree-2 points a single arc of T_C . A consequence is that polytope vertices in the interior of such a path disappear from T_C .

Threading between these possibilities, we define the *combinatorial cut tree* T_C corresponding to a geometric cut tree \mathcal{T}_C as the labeled graph with a node (not necessarily labeled) for each point of \mathcal{T}_C with degree not equal to 2, and a labeled node for each point of \mathcal{T}_C that corresponds to a vertex of Q (labeled by the vertex label); arcs are determined by the polygonal paths of \mathcal{T}_C connecting these nodes. An example is shown in Fig. 8. Note that not every node of the tree is labeled, but every polytope vertex label is used at some node. All degree-2 nodes are labeled.

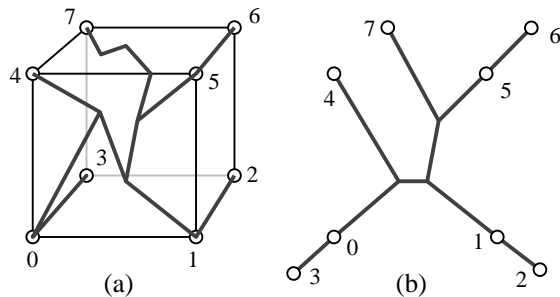

Fig. 8. (a) Geometric cut tree \mathcal{T}_C on the surface of a cube; (b) The corresponding combinatorial cut tree T_C .

This definition has the consequence that, if all degree-2 nodes are removed by contraction, T_C is isomorphic to the corresponding gluing tree T_G . Although the definition avoids some of the listed pitfalls, it does have the undesirable consequence of counting different geodesics on ∂Q between two polytope vertices as the same arc of T_C even if one spirals around the polytope twice and the other once (or not at all).

Before turning to enumeration bounds, we make this straightforward observation: Every polytope admits at least the n cut trees provided by the star-unfolding [AO92], one with each vertex as source. So in particular, every polytope has at least one unfolding to a simple polygon, in contrast to the corresponding open question for edge-unfoldings (p.3).

Our main result here is that some polytopes have an exponential number of unfoldings:

Theorem 6. *There is a polytope Q of n vertices that may be cut open with exponentially many ($2^{\Omega(n)}$) combinatorially distinct cut trees, which unfold to exponentially many geometrically distinct simple polygons.*

Proof: (Sketch) Q is a truncated cone: the hull of two regular n -gons of different radii, lying in parallel planes and similarly oriented. Two different cuttings are illustrated in Figs. 9 and 10. The “base” cut tree, which we notate as $T_{0000000}$,

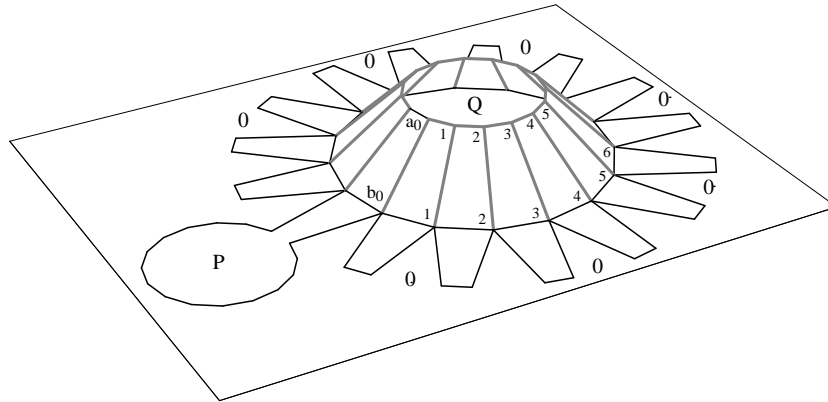

Fig. 9. Unfolding via shaded cut tree $T_{0000000}$.

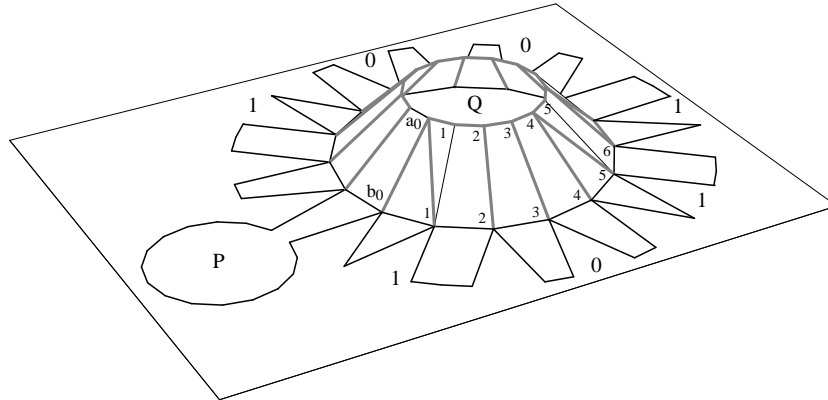

Fig. 10. Unfolding via shaded cut tree $T_{1001101}$.

unfolds Q as shown in Fig. 9. Define a cut tree $T_{m_{(n-1)/2} \dots m_2 m_1 m_0}$, where m_i are the digits of a binary number of $n/2 - 1$ bits, as an alteration of the base tree $T_{0 \dots 0}$ illustrated by $T_{1001101}$ shown in Fig. 10. There are $2^{n/2-1} = 2^{\Omega(n)}$ cut

trees, and it is not difficult to show that each leads to a distinct simple polygon unfolding. \square

We conjecture that there is a polytope with an exponential number of convex unfoldings, i.e., those that result in convex polygons.

Our upper bound relies on bounds on the number of spanning trees of triangulated planar graphs:

Theorem 7. *The maximum number of combinatorially distinct edge-unfolding cut trees of a polytope of n vertices is $2^{O(n)}$, and the maximum number of (arbitrary) combinatorially distinct cut trees is $2^{O(n^2)}$.*

5 Open Problems

Some of the most interesting open questions in this area are algorithmic:

1. Given an Aleksandrov gluing, compute the 3D structure of the polytope. This is an algorithmic version of Aleksandrov’s theorem, for which only a “finite” algorithm is known.⁴ This problem is closely related to the following problem, which may be easier because of the additional information:
2. Given an Aleksandrov gluing and the unique crease pattern for the folding (Cf. Fig. 7), compute the 3D structure of the polytope. This can be viewed as an algorithmic version of Cauchy’s rigidity theorem.
3. How difficult is it to determine whether a given polytope has a convex unfolding? (Cf. Lemma 3.)
4. How difficult is it to determine whether a given polygon may be folded to a polytope? (Cf. Fig. 1.) We have an exponential-time algorithm, but a polynomial time algorithm is known only for edge-to-edge gluings [LO96].

References

- AAOS97. P. K. Agarwal, B. Aronov, J. O’Rourke, and C. A. Schevon. Star unfolding of a polytope with applications. *SIAM J. Comput.*, 26(6):1689–1713, December 1997.
- Ale58. A. D. Aleksandrov. *Konvexe Polyeder*. Akademie-Verlag, Berlin, Germany, 1958.
- AO92. B. Aronov and J. O’Rourke. Nonoverlap of the star unfolding. *Discrete Comput. Geom.*, 8:219–250, 1992.
- BDD⁺98. T. Biedl, E. D. Demaine, M. L. Demaine, A. Lubiw, J. O’Rourke, M. Overmars, S. Robbins, and S. Whitesides. Unfolding some classes of orthogonal polyhedra. In *Proc. 10th Canad. Conf. Comput. Geom.*, pages 70–71, 1998.
- BDEK99. M. Bern, E. D. Demaine, D. Eppstein, and E. Kuo. Ununfoldable polyhedra. In *Proc. 11th Canad. Conf. Comput. Geom.*, pages 13–16, 1999. Full version: LANL ArXive cs.CG/9908003.

⁴ I. K. Sabitov, Oberwolfach presentation, May 2000. See also <http://www.cms.math.ca/CMS/Events/winter98/w98-abs/node46.html>.

- DDLO00. E. D. Demaine, M. L. Demaine, A. Lubiw, and J. O'Rourke. Examples, counterexamples, and enumeration results for foldings and unfoldings between polygons and polytopes. Technical Report 069, Smith College, Northampton, MA, July 2000. LANL ArXive cs.CG/0007019.
- Hir00. K. Hirata. Personal communication, 26 June 2000. Department of Mathematics, Faculty of Education, Ehime University, Japan. <http://weyl.ed.ehime-u.ac.jp/cgi-bin/WebObjects/Polytope2>, 2000.
- LO96. A. Lubiw and J. O'Rourke. When can a polygon fold to a polytope? Technical Report 048, Dept. Comput. Sci., Smith College, June 1996. Presented at AMS Conf., 5 Oct. 1996.
- O'R00. J. O'Rourke. Folding and unfolding in computational geometry. In *Proc. Japan Conf. Discrete Comput. Geom. '98*, volume 1763 of *Lecture Notes Comput. Sci.*, pages 258–266. Springer-Verlag, 2000.
- She75. G. C. Shephard. Convex polytopes with convex nets. *Math. Proc. Camb. Phil. Soc.*, 78:389–403, 1975.

